

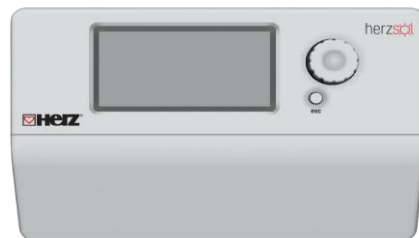

herzsöl

INSTALLATION AND USER MANUAL



Herz Feniks BB d.o.o. Prof. dr Dimitrija Kulića 5, 18202 Niš, Serbia

CONTENTS

DESCRIPTION2
PRECAUTIONS3
CONTROLLER INSTALLATION5
INPUT-OUTPUT CONNECTIONS7
CONNECTION 10
CONNECTION OPTIONS (APPLICATIONS) 13
OPERATING THE SOLAR CONTROLLER.....20
SCREEN LEVELS21
PARAMETERIZATION24
ALARMS29
WARNINGS30

DESCRIPTION

HerzSol is a universal controller that serves as the central control unit for automating and optimizing solar systems and heating/cooling systems. It is designed to ensure reliable and energy-efficient operation, with the ability to adapt to the specific needs of each system.

The controller enables monitoring and precise temperature control, as well as regulation of pumps, valves, and heat exchangers. Thanks to its flexible software architecture, it supports different operating modes (automatic, manual). In solar systems, it provides optimal use of solar energy by controlling circulation pumps and providing protection against overheating and freezing.

In heating and cooling systems, it enables dynamic room temperature control and system operation according to outdoor temperature and schedules. With a simple user interface and LCD display, setup and monitoring are clear and easy to understand. Inputs allow precise system monitoring, while outputs enable control of various actuators (pumps, valves, heaters, fans, etc.).

The controller includes protective functions against overheating, dry running of the pump, and freezing, as well as fault signaling. The controller power supply is 230 V AC / 50 Hz with a battery backup option for saving parameters and settings in case of a power outage. The design is suitable for wall mounting.

PRECAUTIONS



1. Before using the device, read the installation and user manual.
2. Before starting any work, make sure there is no voltage on the terminal strips.
3. **WARNING! – Installation, wiring, and maintenance of the controller must be performed only by qualified and authorized person.**
3. Do not use the device if it is visibly damaged.
4. Use appropriate cable cross-sections according to the manufacturer's recommendations.
5. **WARNING!! - Only an authorized technician may service the device.** If a fault recurs, send the device to the local distributor or service center. In case of improper handling or damage, the manufacturer is not responsible for any consequences.
6. Ensure the housing is properly closed before commissioning.
7. Clean the product with a dry cloth, do not use aggressive cleaning agents.
8. Always secure connection cables to prevent mechanical pull-out or damage.

WARNING! - Work on electrical installations can be dangerous. Before any work, disconnect the main power supply. Verify absence of voltage with an appropriate tester, do not touch electrical connections with wet hands or metal objects. Failure to follow these instructions may result in serious injury or equipment damage. The manufacturer assumes no liability for damages arising from non-compliance with the user manual.

MAINTENANCE: No regular maintenance is required.

WARRANTY: The manufacturer guarantees correct operation of the solar controller only in case of proper installation and handling. A fault report should include: controller type, serial number, installation site, and fault description. Faults due to mechanical damage or poor-quality power supply are not covered by the warranty.

SERVICE: Service is provided by the manufacturer during and after the warranty period. Always disconnect power before opening the housing or performing any intervention.

DISPOSAL (WEEE Directive): At end of life, dismantle the product, sort components by material, and hand them over to authorized waste collection and recycling organizations in accordance with local regulations.

CONTROLLER INSTALLATION

General installation conditions:

- Install the controller in a dry area, protected from moisture, dust, and direct sunlight.
- Ambient temperature range must comply with the device technical specifications.
- Do not expose to sources of vibration or mechanical shock.
- The mounting surface must be flat, rigid, and suitable for stable fixing of the device.

Installation steps (wall mounting):

- Determine the controller mounting location.
- Drill holes and install screw plugs (if required).
- Fasten the device with screws.
- Route cables through the provided controller openings and secure the strain relief with screws.
- Provide sufficient clearance on all sides (min. 5 cm) for access and cooling.
- **WARNING!** – Incorrect installation may cause device damage, void the warranty, and lead to electric shock hazards.

NOTE: A set of temperature sensors is supplied with the controller. Sensor on the collector (blue), sensors for the water heater, pool, tank (green).

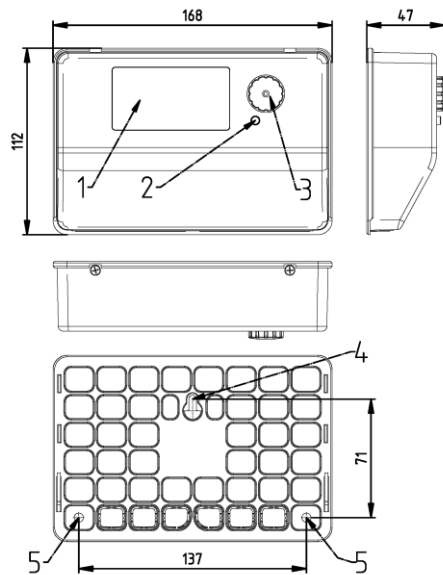

1. Controller display (128 x 64 pixels)
2. ESC key
3. Rotary knob
4. Hole for wall mounting
5. Holes for mounting on the wall

The housing is made of polycarbonate plastic, with IP 20 protection, dimensions 112 x 168 x 47 (W x H x D), weight 0.4 kg. Suitable ambient temperature 0 – 50 °C.

Figure 1. Controller dimensions

INPUT-OUTPUT CONNECTIONS

Power supply:

- Input voltage: 230V AC / 50Hz,

Digital outputs:

- **TRC1 – TRC4:** Triac outputs for controlling pumps, valves and heaters, max load 16A / 230 VAC,
- **RELAY1, RELAY2:** Relay outputs for high-power devices (pumps, heaters, etc.), max load 16A / 230 VAC.

Digital inputs (DIN1–DIN4):

- Inputs for thermostats, switches, sensors, etc.,
- Optocoupler isolation for increased safety,
- Operating voltage 12 VDC (internal).

Analog outputs:

- **VOUT1 (0-10 V):** for proportional control of valves, fans...

Analog inputs:

- **RTD1 - RTD5 (S1-S5):** inputs for Pt1000 temperature sensors,
- **VIN1:** input for voltage signal (0-10 V),
- **AIN1:** input for current signal (4-20mA).

PWM Output:

- Connection to HE pumps with variable speed (PWM control).

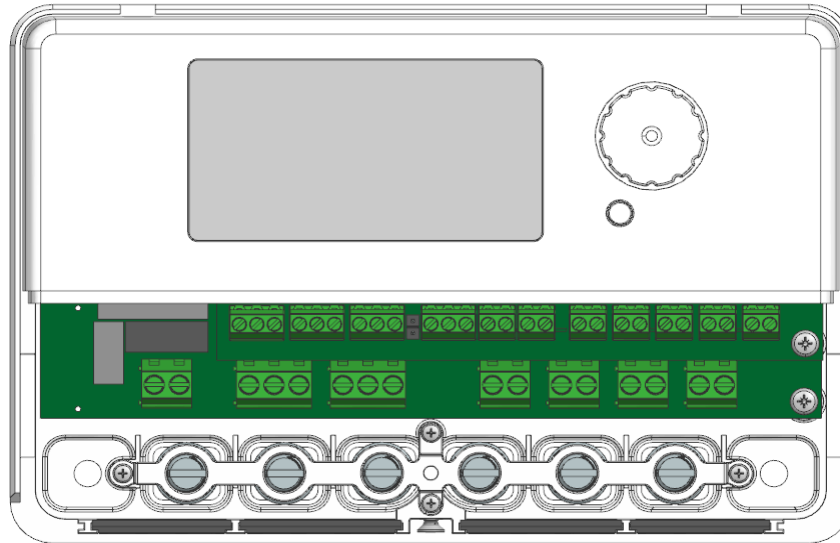

Figure 2. Controller without bottom cover

In order to connect the measuring and regulating equipment and actuators (pumps, fans, valve drives) to the controller, it is necessary to remove the bottom cover. The bottom cover is removed by unscrewing the screw located on the underside of the controller. (Figure 3)

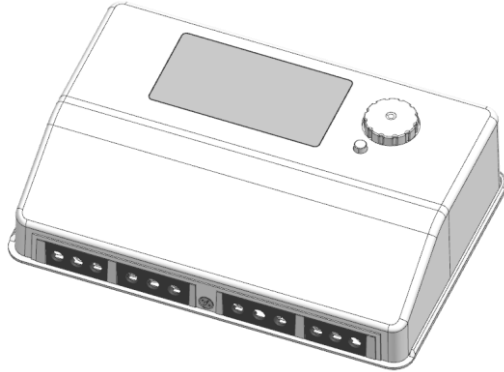

Figure 3. Controller with bottom cover

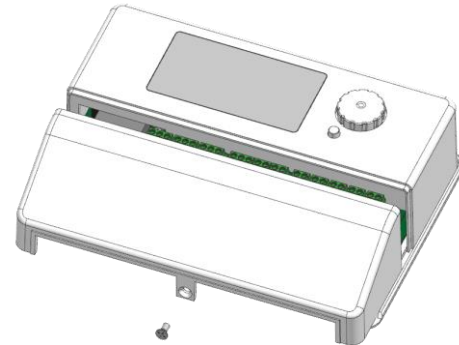

Figure 4. Bottom cover removal

CONNECTION

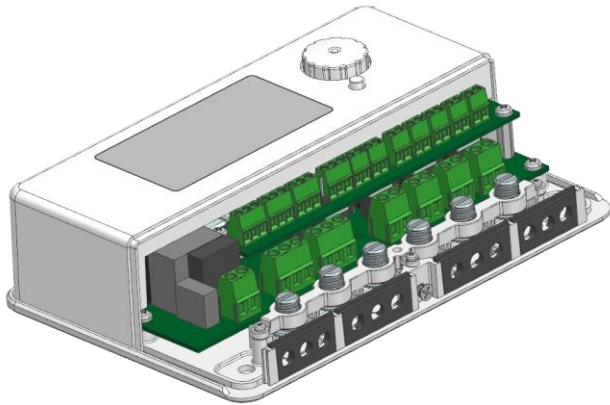

Figure 5. Controller without bottom cover

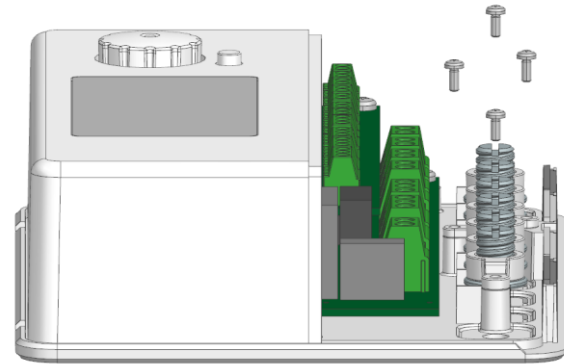

Figure 5.1 Cable management profile removal

After removing the bottom cover (Figure 4), remove the cable management profile. Route cables through the rubber grommets. To prevent cables from being pulled out of the terminals, place the cable management profile over the cables (Figure 5.1). This prevents mechanical damage caused by pulling the conductors.

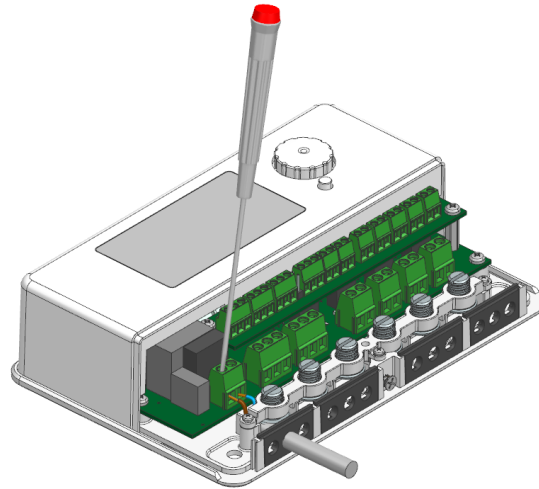

Figure 5.2 Wiring example

NOTE: Recommended mains cable: PP/L H03VV-F 2x0.75mm².

NOTE: Controller outputs are assigned according to the application's control functions. (see Figure 6)



Figure 6. Digital outputs

Relay output 1 (Relay 1) is reserved for an external heater, while Relay 2 is reserved for a dump valve.

NOTE: The conductor cross-section for larger consumers must be selected in accordance with the consumer's technical data.

Triac digital outputs are reserved for the following peripheral devices:

1. TRIAC OUT 1 – solar pump,
2. TRIAC OUT 2 – second system pump,
3. TRIAC OUT 3 – valve 3,
4. TRIAC OUT 4 – valve 4.

NOTE: Recommended sensor cables (if not supplied with sensors): SiHF 2x0,5mm² or shielded LiYCY 2x0,75mm².

NOTE: Cable lengths over 100 m may increase susceptibility to EMC interference.

NOTE: The controller does not contain an internal pump power supply so provide an external source as per specifications.

CONNECTION OPTIONS (APPLICATIONS)

Solar with storage tank

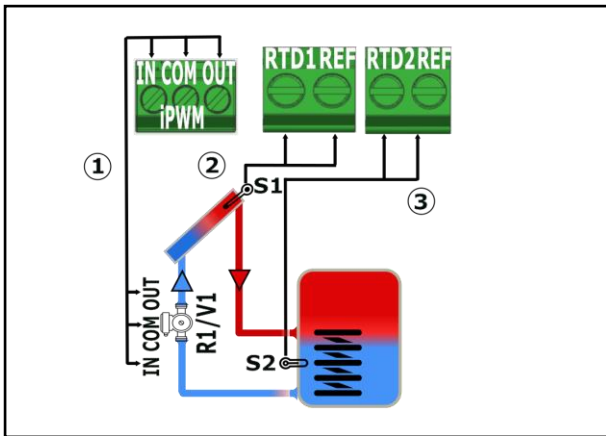

Solar with pool

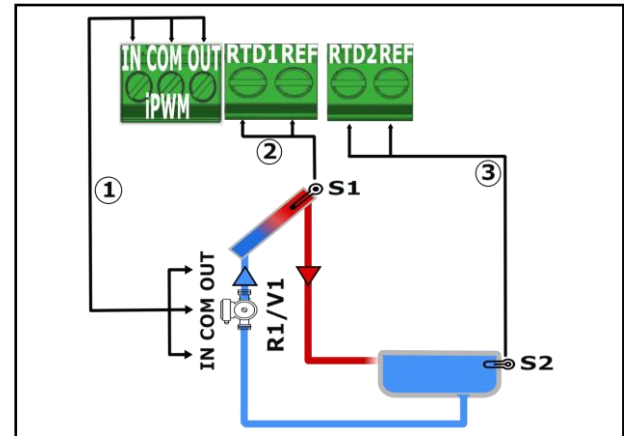

Solar with solid-fuel boiler

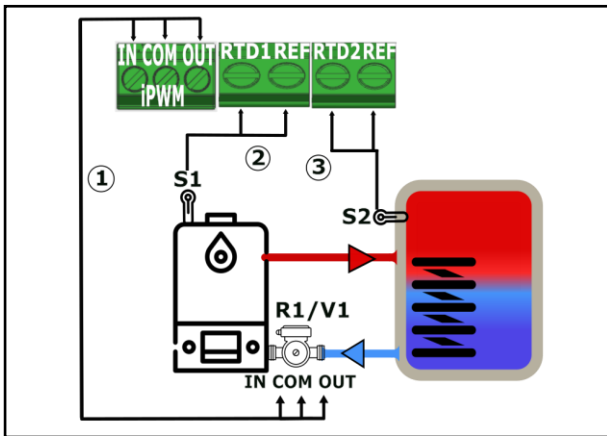

Solar and room thermostat

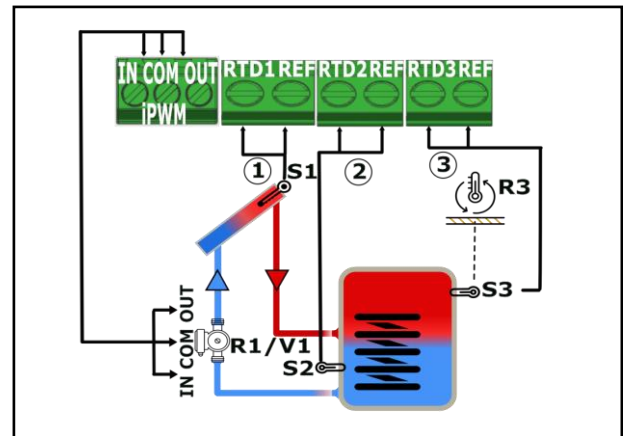

Solar with storage tank in 2 zones

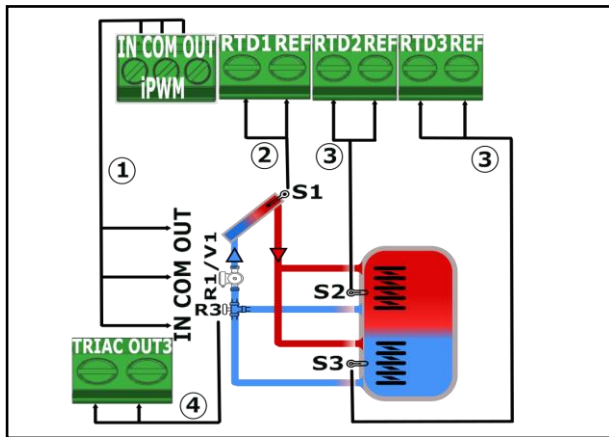

Solar with radiators and water heater

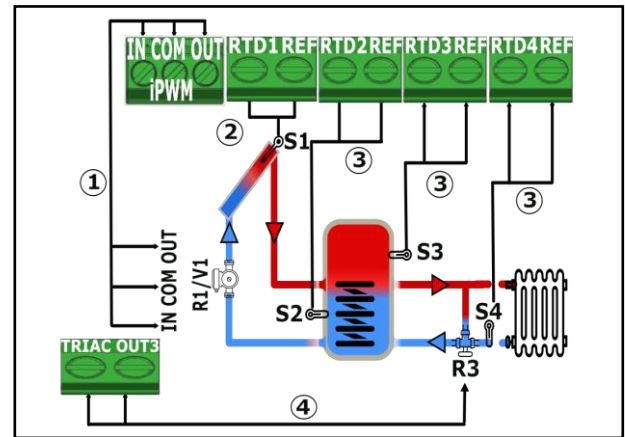

Solar with two tanks and a valve

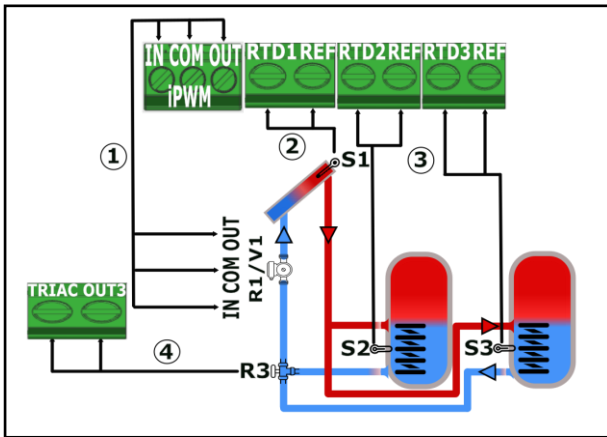

Solar with DHW auxiliary heating

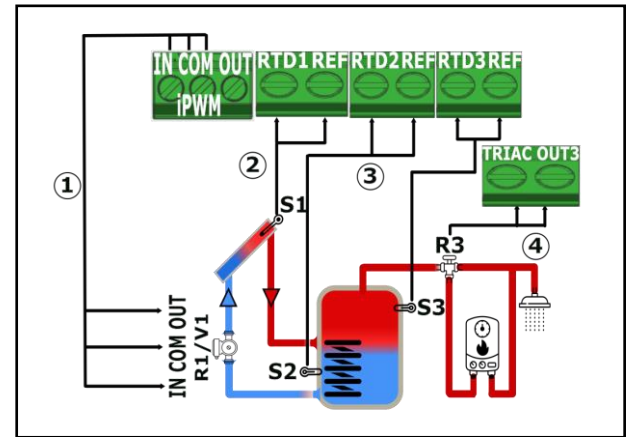

Solar with pool, storage tank and heat exchanger

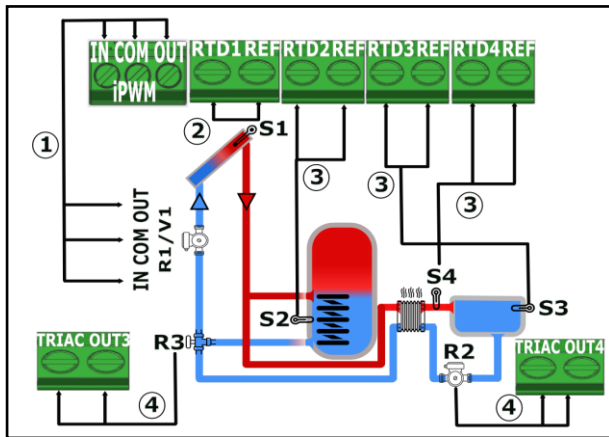

Solar with three tanks and two valves

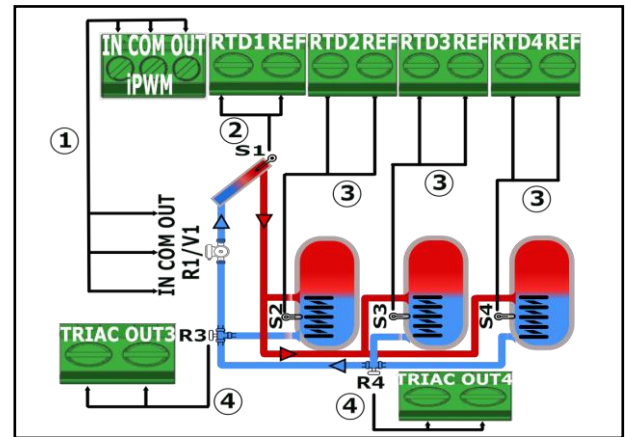

In the application diagrams, circled numbers denote conductors:

1. Cable for the PWM pump (two wires): use brown (Input) and blue (GND). If three wires: brown (Input), blue (GND), black (Output),
2. The collector sensor cable is usually supplied with the sensor; otherwise, use SiHF 2x0,5mm²,
3. For other sensors, use SiHF 2x0,5mm² ili LiYCY 2x0,75mm²,
4. Triac output cabling depends on load power: PP/L H03VV-F 2x0,75mm² to PP/L H03VV-F 2x1,5mm²

For larger valve actuators, use JY(St)Y 2X2X0,8mm².

WARNING! – Jumper J17 (Figure 7) is bridged, which means the controller's internal 12 V supply can be used.

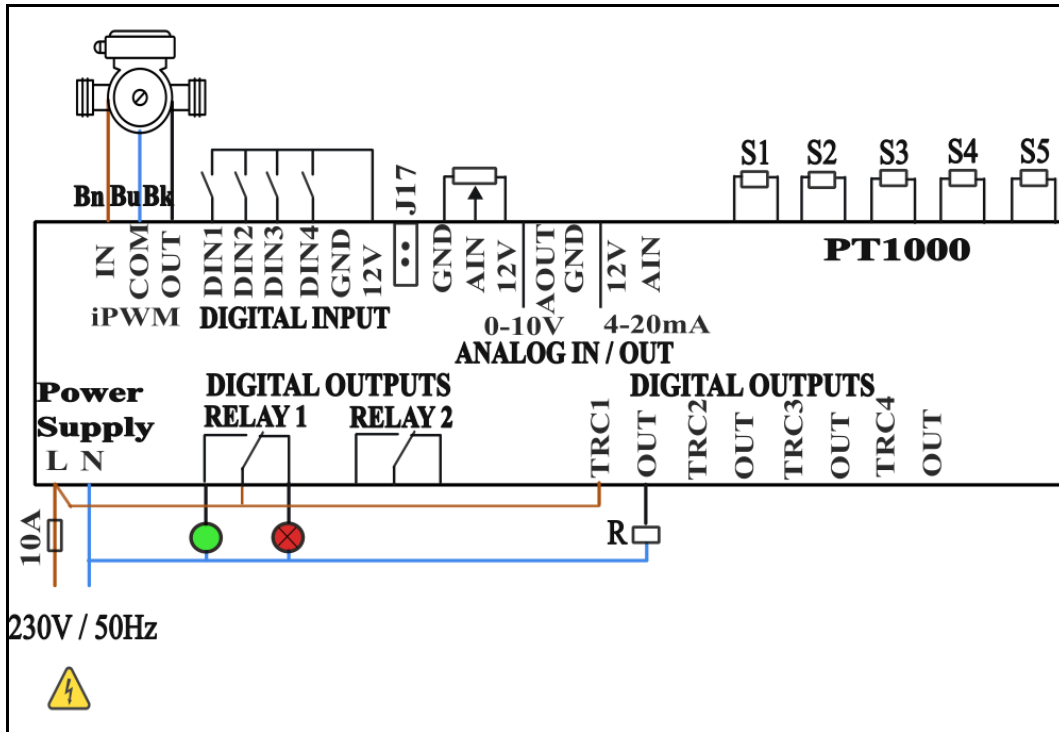
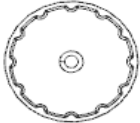



Figure 7. Example wiring with measuring/control equipment

OPERATING THE SOLAR CONTROLLER

Controller keys	Functions
<p>ROTARY KNOB</p> 	<p>Go to next menu level; change values by rotation. Press to confirm values and enter submenus.</p>
<p>ESC KEY</p> 	<p>Return to previous menu level or exit value-edit screen without saving.</p>

NOTE: If no action is taken for more than 10 minutes, the display turns off. Press any key to wake it.

SCREEN LEVELS

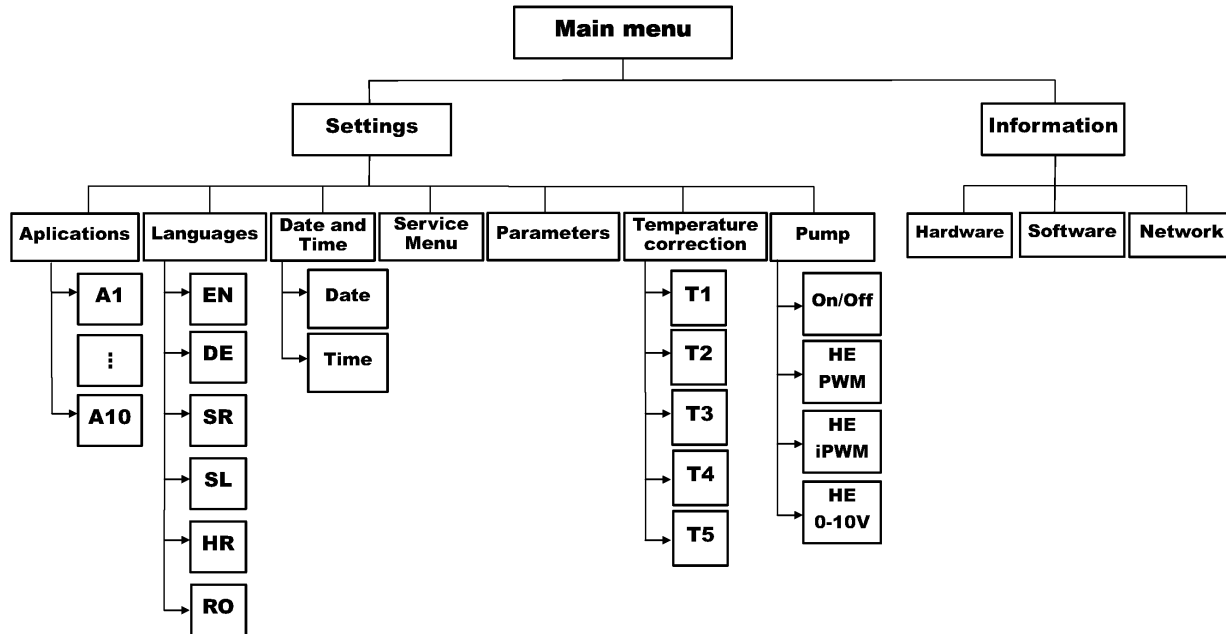

Figure 8. Menu and submenu layout

At power-up, the currently active application is shown. Press the rotary knob to open the Main menu. It contains the submenus “Settings” and “Info”. By turning the rotary knob, the user selects the desired submenu, by pressing the rotary knob, he confirms and enters it. If the user wants to return from the selected submenu, he needs to press the ESC key.

The **Settings** menu contains:

1. **Solar App (applications)**

- ❖ Select one of the predefined solar applications (A1 ... A10).
- ❖ Each application corresponds to a specific system mode.

2. **Languages**

- ❖ Select the language;
- ❖ Available languages:
 - EN (English)
 - DE (German)
 - SR (Serbian)
 - SL (Slovenian)
 - HR (Croatian)
 - RO (Romanian)

3. **Date & Time**

- ❖ Set date (day, month, year) and time (hour, minute).
- ❖ Submenus:
 - *Dates* - setting day, month and year.
 - *Time* - hour and minute setting.

4. Service

- ❖ **Only available to authorized service technicians.**

- ❖ Submenus:

- *Manual Mode* - manual output control.
- *Burn In Test* - system load testing.
- *LVD & EMC* - shielding and electromagnetic compatibility tests.

5. Solar Params

- ❖ Set solar system operating parameters according to the installation.

6. Temperature Offsets

- ❖ Sensor temperature offset correction.

- ❖ Submenus: T1, T2, T3, T4, T5.

7. Pump

- ❖ Pump type selection:

- *On/Off* - turning the pump on and off,
- *HE PWM* – high efficiency pump without status,
- *HE iPWM* – high efficiency pump with statuses,
- *HE (0-10V)* - high efficiency voltage controllable pump.

The **Info** allows viewing technical data about the device:

- ❖ **Hardware** - shows the version of the hardware platform,

- ❖ **Software** - shows the installed software version,

- ❖ **Network** - displays network information and communication status.

PARAMETERIZATION

No.	Parameter	Range	Description
1.1	Language	EN , DE, SR, SL, HR, RO	EN – English, DE – German, SR - Serbian, SL – Slovenian, HR - Croatian, RO – Romanian.
1.2	Date	Day.Month.Year	System calendar
1.3	Time	Hour:Minute	System time
2.1	T1offs	-10K – +10K (0K)	Temperature offset on sensor 1
2.2	T2offs	-10K – +10K (0K)	Temperature offset on sensor 2
2.3	T3offs	-10K – +10K (0K)	Temperature offset on sensor 3
2.4	T4offs	-10K – +10K (0K)	Temperature offset on sensor 4
2.5	T5offs	-10K – +10K (0K)	Temperature offset on sensor 5
Solar			

parameters			
3.1	dTmax	5K – 20K (6K)	dT = Tcollector – Tstorage. When dT ≥ dTmax, the solar pump turns ON.
3.2	dTmin	2K – 6K (3K)	dT = Tcollector – Tstorage. When dT ≤ dTmin, the solar pump turns OFF.
3.3	Solar pump type	(i)PWM , V10, ON/OFF	(i)PWM – (i)PWM pump; V10 – 0–10 V pump; ON/OFF – on/off pump.
3.4	PPmax	50 – 100% (100%)	Maximum power of the high-efficiency solar pump.
3.5	PPmin	10 – 50% (25%)	Minimum power of the high-efficiency solar pump.
Temperature parameters			
4.1	TcolectorMAX	0 - 99°C (99°C)	Maximum temperature at the collector.
4.2	TS1max	0 - 99°C (80°C)	Maximum temperature in storage tank 1.

4.3	TS2max	0 - 99°C (80°C)	Maximum temperature in storage tank 2.
4.4	TS3max	0 - 99°C (80°C)	Maximum temperature in storage tank 3.
4.5	TS1min	0 - 99°C (35°C)	Minimum temperature in storage tank 1.
4.6	TS2min	0 - 99°C (35°C)	Minimum temperature in storage tank 2.
4.7	TS3min	0 - 99°C (35°C)	Minimum temperature in storage tank 3.
4.8	TPoolmax	0 - 40°C (35°C)	Maximum pool temperature.
Reduced consumption parameters			
5.1	Vacation	ON, OFF	Solar system mode with reduced DHW consumption.
Pump protection parameters			
6.1	SeizePP	ON, OFF	Pump anti-seize protection enabled.

6.2	SeizePP_Time	00:00 – 23:59 (12:00)	Activation time if the pump hasn't run for more than 24 h.
6.3	SeizePP_Run	10 – 60s (30s)	Duration of protective pump run.
Frost protection parameters			
7.1	AntiFrost	ON, OFF	Anti-frost protection enabled.
7.2	AntiFrost_T	-15 – +5°C (0°C)	Temperature at which protective pump run is activated.
Overheating protection parameters			
8.1	OverheatP	ON, OFF	Overheat protection enabled.
Parameters of protection against			

legionella			
9.1	AntiLegionalla	ON, OFF	Anti-legionella protection enabled.
9.2	AntiLegionalla_T	55 - 65°C (60°C)	Protection temperature.
9.3	AntiLegionalla_I	1 – 7 dana (7 dana)	Protection interval.
9.4	AntiLegionalla_R	30 – 120 min (60 min)	Protection duration.
Additional heater parameters			
10.1	AuxHeater	ON, OFF	Auxiliary heater enabled.
10.2	AuxHeater_DTon	00:00 – 23:59 (15:00)	Start of auxiliary heating window.
10.3	AuxHeater_DToff	00:00 – 23:59 (09:00)	End of auxiliary heating window.

NOTE: Values in parentheses are factory defaults.

ALARMS

No.	Alarm	Description
1.1.1	Sensor 1 OPEN	Sensor S1 disconnected.
1.2.1	Sensor 2 OPEN	Sensor S2 disconnected.
1.3.1	Sensor 3 OPEN	Sensor S3 disconnected.
1.4.1	Sensor 4 OPEN	Sensor S4 disconnected.
1.5.1	Sensor 5 OPEN	Sensor S5 disconnected.
1.1.2	Sensor 1 CLOSE	Sensor S1 short circuit.
1.2.2	Sensor 2 CLOSE	Sensor S2 short circuit.
1.3.2	Sensor 3 CLOSE	Sensor S3 short circuit.
1.4.2	Sensor 4 CLOSE	Sensor S4 short circuit.
1.5.2	Sensor 5 CLOSE	Sensor S5 short circuit.
2.1.1	Pump error	Pump operation error.
2.1.2	No Flow	Within 5 minutes the pump did not reduce $dT \geq dT_{max}$.
2.1.3	Pump control oscillation	More than 5 ON/OFF cycles within 5 minutes.
3.1.1	Collector Overheating	Collector overheated $T_{collector} \geq dT_{collectorMAX}$
3.1.2	Collector Frozen	Collector frozen
4.1.1	Storage 1 overheating	Storage tank 1 overheated

		$T_{\text{storage1}} \geq T_{\text{storageMAX}}$
4.2.1	Storage 2 overheating	Storage tank 2 overheated $T_{\text{storage2}} \geq T_{\text{storageMAX}}$
4.3.1	Storage 3 overheating	Storage tank 3 overheated $T_{\text{storage3}} \geq T_{\text{storageMAX}}$
4.4.1	Pool overheating	Pool overheated $T_{\text{pool}} \geq T_{\text{poolMAX}}$

WARNINGS

No.	Warnings	Description
	Restart	
1.1	Date&Time settings	System calendar and time are not set.
2.1	Vacation mode	Vacation mode (reduced DHW consumption) active. Possible losses due to releasing surplus heat through the collector or dump valve.
2.2	Antilegionella active	Anti-legionella mode active.
2.3	Collector protection	Collector overheat protection active.